

PRODUCT DATA SHEET

SXMV3.5G32D-F24 - 3400 RPM

DESCRIPTION

Plunger Pumps are designed for high-pressure industrial washing applications. They are constructed of die-cast bodies and feature a forged brass heads with a bayonet style sight glass in the rear and side covers. Internal components include special thick solid ceramic plungers for long life and durability. Precision cast cooling fins are anodized for maximum heat dissipation. Oversized premium SKF tapered roller bearings and the precision die-cast supports assure proper shaft alignment and maximum life. Valve cages of Ultra-Form provide positive seating and extended life, especially designed for high pressure applications. Two-piece connecting rods are a special alloy aluminum-based material oversized for maximum strength and load disbursement. Spinning at 1750 RPM, this pump was designed to deliver 4 GPM at 4000 PSI.



SPECIFICATIONS

MAX GPM	3.5	MAX LMP	13.2
MAX PSI	3200	MAX BAR	220
POWER EBHP	7.7	BORE DIA. MM	15
STROKE MM	8.2	WEIGHT LBS	16
MAX TEMP	140°	OIL CAPACITY	14.6oz
INLET THREAD	1/2" F	DISCHARGE THREAD	3/8" F

DIMENSIONS

SXMV

D version + F24
Hollow shaft pump ø 1"

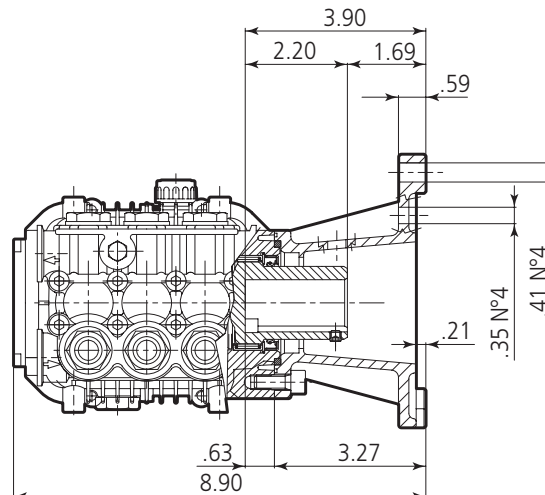
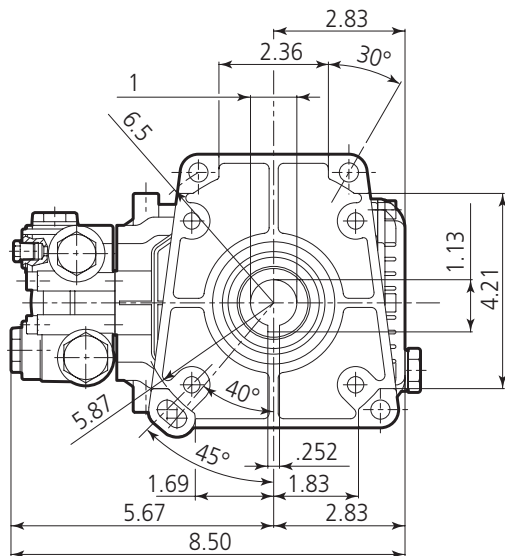

SPECIAL FEATURES

WET END

- **Manifold:**
 - **Forged Brass:** Strength and no porosity equals long life. Higher hydrostatic pressures, safety and performance.
 - **Inlet and Discharge Ports:** Heavy bosses for added strength.
 - **Offset Discharge Ports:** High efficiency, smooth flow.
 - **Bolts:** Eight bolts, 6mm, grade 12.9.
- **Valves:**
 - **Ultra Form Cages:** Durability, strength and long life.
 - **Poppets, Seat and Spring:** 303 and 400 series stainless steel.
 - **Valve Caps:** Machined brass – greater strength.
- **Packing and Plungers:**
 - **High Pressure Packing:** "V" style (D-1) Buna-N (cotton duct weave base) strong and tightens under load.
 - **Low Pressure Seals:** "U" cup double lip Buna-N, good positive seal.
 - **Support Guides:** Machined brass, two-piece construction to assure proper plunger alignment and to maximize packing and seal life.
 - **Plungers:** Are a special aluminum oxide blend, solid ceramic for long life, strong durability and more resilient.

DRIVE END

- **Bearings:** Oversized for maximum life and load disbursement, needle bearing on the drive side and ball on the non-drive side. Each bearing is held in position on the crankshaft and crankcase by snap rings. This assures positive alignment and centering of the connecting rods and crankshaft in relation to the crankcase, it also eliminates the crankshaft from floating.
- **Crankcase:** Precision die-cast, large cooling fins and anodized (for maximum heat dissipation).
- **Rear Cover:** precision die-cast, O-ring sealed and bayonet style sight glass for positive sealing and locking (no threads to loosen).

- **Plunger Rods:** Stainless steel construction for strength (no plating to scrape off). O-ring plunger sealing system.
- **Rod Pins:** Precision ground and hardened steel, oversized for load disbursement.
- **Connecting Rods:** One-piece special alloy aluminum based, oversized for maximum strength, load disbursement, and life. Heavy pin area construction, for added load strength.
- **Crankshaft:** Forged, precision ground and hardened for extremely long life and durability.
- **Oil Seals and O-rings:** All are constructed of Buna-N rubber. The O-rings have stainless steel garter springs to assure constant tension on the sealing surface.
- **Oil Capacity:** 14.5 oz., refer to parts breakdown.

EXTRA FEATURES

- **Dyno Proven:** All pumps are dyno tested to assure the theoretical design meets the actual design.
- **Valve Design:** Each pump series has a valve design that optimizes its highest efficiency.
- **Hot Water:** High temperature kits are available to 180° F. Refer to breakdown
- **Wet End Repair:** Very simple no special tools are required.
- **Mounting Bolt Pattern:** Same on the top and bottom of the crankcase for simple drive side change.
- **Design:** Using advanced fluid handling design programs. Overall pump efficiency is increased.