

### DESCRIPTION

Plunger Pumps are designed for a wide variety of high pressure washing applications. They are constructed of die-cast bodies and feature a forged brass head. Internal components include special thick solid ceramic plungers for long life and durability. Precision cast cooling fins are anodized for maximum heat dissipation. Oversized tapered roller bearings and the precision supports assure proper shaft alignment and maximum life. Valve cages of special designed Ultra-Form provide positive seating and extended life. One-piece connecting rods are either a special alloy aluminum or bronze oversized for strength and load disbursement. These pumps are designed for gearbox, belt drive, or coupling drive systems, electric motor 182-184 frame driven systems, or gasoline engine driven systems.



### SPECIFICATIONS

MAX GPM .....	3.5	MAX LMP .....	13.2
MAX PSI.....	2500	MAX BAR .....	170
POWER EBHP .....	5	BORE DIA. MM.....	18
STROKE MM.....	10.8	WEIGHT LBS.....	19
MAX TEMP .....	140°	OIL CAPACITY.....	15oz
INLET THREAD .....	1/2" F	DISCHARGE THREAD .....	3/8" F

### DIMENSIONS

RKA N version  
Solid shaft pump / ø 24 mm

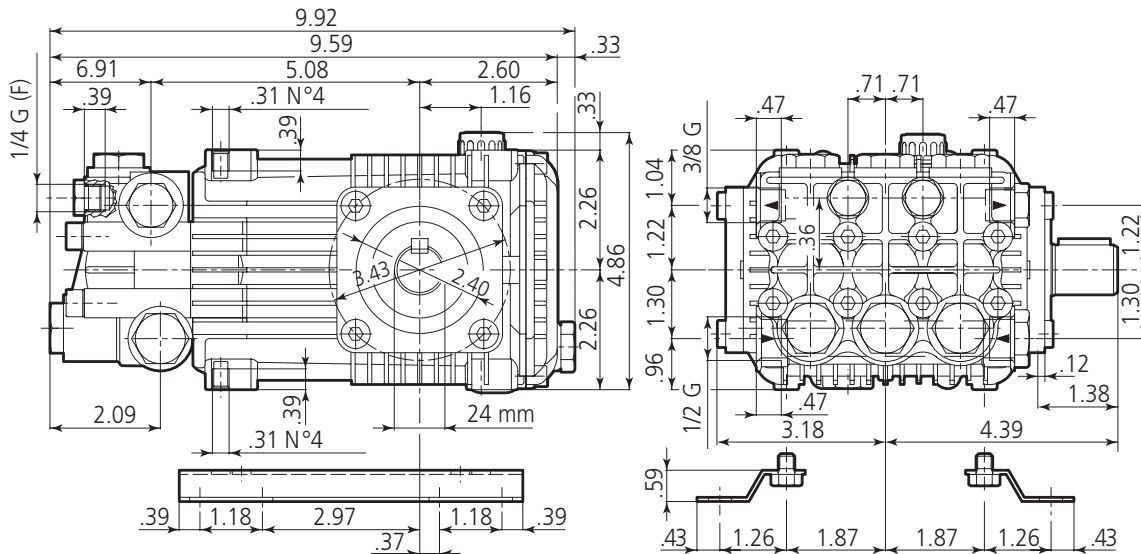

## SPECIAL FEATURES

### WET END

- **Manifold:**
  - **Forged Brass:** Strength and no porosity – long life. higher hydrostatic pressures – safety, performance.
  - **Inlet and Discharge Ports:** Heavy bosses for added strength.
  - **Offset Discharge Ports:** High efficiency, smooth flow.
  - **Bolts:** Eight bolts, 8mm, grade 8.8.
- **Valves:**
  - **Valve Caps:** Stainless steel on pumps rated at 3200 PSI and higher, better hydrostatic loads. Machined brass on pumps <3200 PSI.
  - **Ultra Form Cages:** Durable, strength, and long life.
  - **Poppets, Seat and Spring:** 303 and 400 series stainless steel.
- **Packing and Plungers:**
  - **High Pressure Packing:** "V" style (D-1) Buna-N (cotton duct weave base) strong and tightens under load.
  - **Low Pressure Seals:** "U" cup double lip Buna-N for a good positive seat.
  - **Support and Guides:** Machined brass, 1-piece construction to assure proper plunger alignment and to maximize packing and seal life.
  - **Plungers:** Are a special aluminum oxide blend, solid ceramic for long life, strong durability and more resilient.

- **Plunger Rods:** Stainless steel construction for strength (no plating to scrape off), back-up and O-ring plunger sealing system.
- **Rod Pins:** Precision ground and hardened steel, oversized for load disbursement.
- **Connecting Rods:** One-piece special allow aluminum or bronze for higher pressure, oversized for maximum strength, load disbursement, and life. Heavy pin area construction, for added load strength.
- **Crankshaft:** Forged, precision ground and hardened for extremely long life and durability.
- **Oil Seals and O-rings:** Triple lip oil seals, long life and much less leak prone. All are constructed of Buna-N rubber. The O-rings have stainless steel garder springs to assure constant tension on the sealing surface.
- **Oil Drains:** Quantity of two (2). One in the rear cover and one in the bottom of the crankcase.
- **Oil Capacity:** 15.5 oz.

### EXTRA FEATURES

- **Dyno Proven:** All pumps are dyno tested to assure the theoretical design meets the actual design.
- **Valve Design:** Each pump series has a valve design that optimizes its highest efficiency.

### DRIVE END

- **Bearings:** Oversized tapered roller bearing for maximum life and load disbursement.
- **Bearing Support:** Precision die-cast and machined to assure concentricity and alignment.
- **Crankcase:** Precision die-cast, large cooling fins and anodized (for maximum heat dissipation).
- **Rear Cover:** Precision die-cast, O-ring sealed and bayonet style sight glass for positive sealing and locking (no threads to loosen).