

DESCRIPTION

Industrial triplex car wash pumps a perfect marriage with any vehicle wash system. Belt-driven or direct-drive pumps are specially designed for the purpose of Car Wash equipment and Car Wash supply. Specially designed seals, huge connecting rods, super thick ceramic plungers, premium bearings and forged brass manifold (with a lifetime warranty) insure the pump will give years of continuous, trouble free service. AR heavy-duty car wash pumps provide low maintenance and allow service to be quick and affordable.



SPECIFICATIONS

MAX GPM 3.96
 MAX PSI..... 2200
 POWER EBHP 5.5
 STROKE MM..... 14.6
 MAX TEMP 140°
 INLET THREAD 1/2" F

MAX LMP..... 15
 MAX BAR 150
 BORE DIA. MM..... 18
 WEIGHT LBS..... 21
 OIL CAPACITY..... 15oz
 DISCHARGE THREAD 3/8" F

DIMENSIONS

RCW N version
 Solid shaft pump ø 24 mm

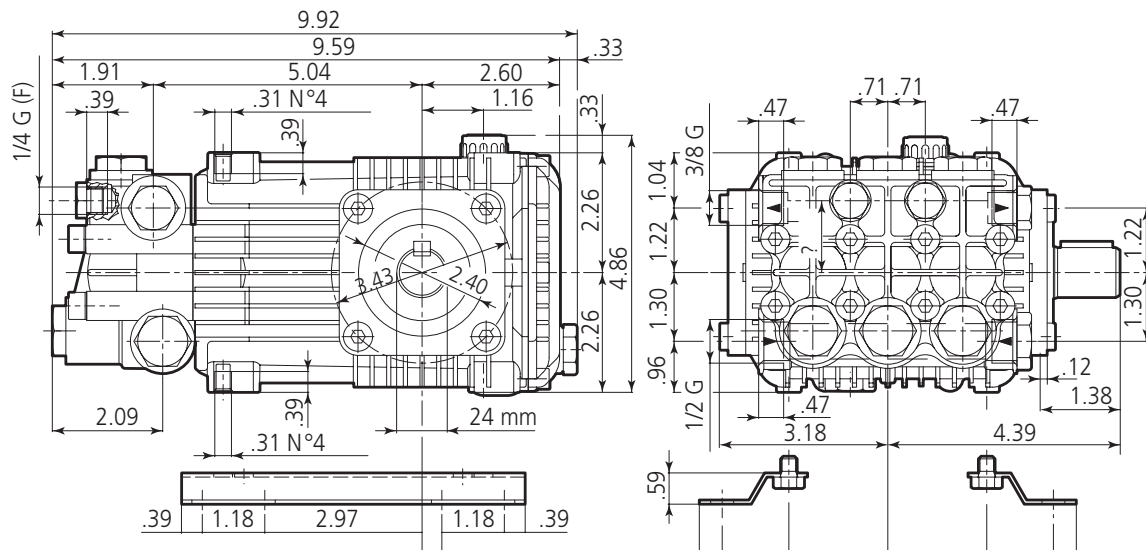

SPECIAL FEATURES

WET END

- **Manifold:**
 - **Forged Brass and Nickel Plating:** Strength and no porosity – long life. higher hydrostatic pressures – safety, performance.
 - **Inlet and Discharge Ports:** Heavy bosses for added strength.
 - **Offset Discharge Ports:** High efficiency, smooth flow.
 - **Bolts:** Eight bolts, 8mm, grade 8.8. Stainless steel.
- **Valves:**
 - **Valve Caps:** Stainless steel, higher, better hydrostatic loads.
 - **Ultra Form Cages:** Durable, strength, and long life.
 - **Poppets, Seat and Spring:** 303 and 400 series stainless steel.
- **Packing and Plungers:**
 - **High Pressure Packing:** "V" style (D-1) Buna-N (cotton duct weave base) strong and tightens under load.
 - **Low Pressure Seals:** "U" cup double lip Buna-N for a good positive seat.
 - **Support and Guides:** Machined brass, 1-piece over sized construction to assure proper plunger alignment and to maximize packing and seal life.
 - **Plungers:** Are a special aluminum oxide blend, solid ceramic for long life, strong durability and more resilient. Ultra thick wall.

DRIVE END

- **Bearings:** Oversized tapered roller bearing for maximum life and load disbursement. Premium SKF.
- **Bearing Support:** Precision die-cast and machined to assure concentricity and alignment.
- **Crankcase:** Precision die-cast, large cooling fins and coating (for maximum heat dissipation and chemical resistance).
- **Rear Cover:** Precision die-cast, O-ring sealed and bayonet style sight glass for positive sealing and locking (no threads to loosen).

- **Plunger Rods:** Stainless steel construction for strength (no plating to scrape off), back-up and O-ring plunger sealing system.
- **Rod Pins:** Precision ground and hardened steel, oversized for load disbursement.
- **Connecting Rods:** One-piece bronze for higher pressure, oversized for maximum strength, load disbursement, and life. Heavy pin area construction, for added load strength.
- **Crankshaft:** Forged, precision ground and hardened for extremely long life and durability. Available in 24mm solid shaft, hydraulic motor and gear box drives. Shaft key set screws are standard on high speed version for long shaft life.
- **Oil Seals and O-rings:** Triple lip oil seals, long life and much less leak prone. All are constructed of Buna-N rubber. The O-rings have stainless steel garter springs to assure constant tension on the sealing surface.
- **Oil Drains:** Quantity of two (2). One in the rear cover and one in the bottom of the crankcase. Stainless steel plugs.
- **Ports:** Two 1/4" discharge ports.
- **Oil Capacity:** 15.5 oz.

EXTRA FEATURES

- **Dyno Proven:** All pumps are dyno tested to assure the theoretical design meets the actual design.
- **Valve Design:** Each pump series has a valve design that optimizes its highest efficiency.
- **Hot Water:** High temperature kits are available to 180°F.
- **Wet End Repair:** Very simple no special tools are required.
- **Design:** Using Advanced Fluid Handling Design Programs. Overall Pump Efficiency is increased.